



**Eldex**

Tel: (707) 224-8800  
30 Executive Court  
Napa, CA 94558-6278  
USA

Eldex Laboratories, Inc.  
(800) 969-3533  
Fax: (707) 224-0688  
email: service@eldex.com

# Instructions

## Piston Seal Replacement for Optos PEEK 1/4" Piston Pumps Rev. A

1. Use tools supplied with Eldex Part Nos. 5925 (1/4" diameter dowel pin and 5/32" hex key).
2. Send the piston to the home position. Turn the power switch to OFF.
3. Remove liquid end from pump as follows: Unscrew the two 5/32" socket head bolts. Pull the liquid end straight out from the pump housing, in line with the axis of the piston. If you cock or tilt the liquid end, you may break the piston. See Figure 1.

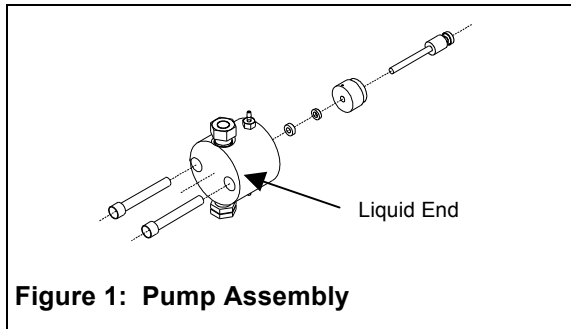

**Figure 1: Pump Assembly**

4. Remove the retainer/wash from the liquid end, and insert the installation tool into the liquid end through the piston seal (if your pump uses a 3/32" or 1/8" diameter piston, the installation tool has a "hooked" end, which is used to remove the seals). If you are using the installation tool, hook the existing seals and remove and discard both the washer (if present) and the seal. If you are using the 1/4" dowel pin, rock the dowel pin back and forth gently, and remove and discard both the washer (if present) and seal. Do not scratch the walls of the piston seal gland in the liquid cylinder with the tool.

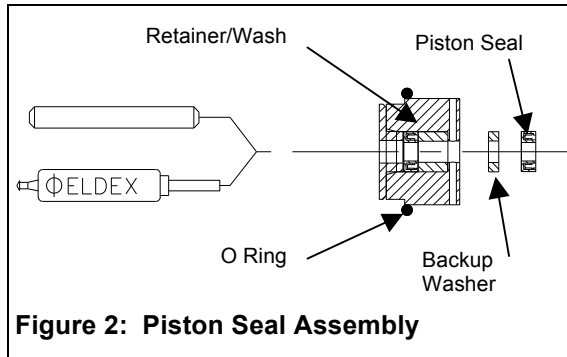

**Figure 2: Piston Seal Assembly**

5. Inspect the piston. You can remove the piston by moving the piston up in the slot which holds it in place. If the piston has scratches on the sapphire, or significant corrosion on the stainless steel piston holder, you should replace it. If there is minor corrosion on the piston holder, clean the piston holder. Also inspect for evidence of deposits on the sapphire. If deposits are present (discoloration of, or particulates on, the sapphire), clean the sapphire. If the sapphire does not clean up, the piston should be replaced.
6. Inspect the retainer. Clean the retainer/wash if necessary. If there is evidence of wear, or if the piston does not fit snugly in the retainer/wash, or if the retainer grips the piston too tightly, you should replace the retainer/wash.
8. Inspect the liquid cylinder, paying special attention to the gland for the piston seal. Any scratches or irregularities will require replacement of the liquid end.

9. Clean all parts with a liquid detergent, followed by a rinse. Clean any fluid in the mechanical end of the pump.
10. Insert the installation tool /dowel pin into the retainer and then into the new seal backup washer (present only on 1HI, 2HI, and 3HI models) and new piston seal. When inserting the tool through the new piston seal, the piston seal should lay flat on a hard surface with the open side down (the seal will generally "snap" onto the tool). Position the parts on the tool as shown in Figure 2. Line up the holes in the retainer/wash with the wash ports on the liquid end. Insert the tool into the liquid end bore as shown in Figure 3. **CAUTION:** the open side of the seal (side revealing the spring or the O ring) should face the closed (fluid side) end of the liquid end.
11. Keeping the tool perpendicular with the face of the liquid end, push the piston seal and washer into the liquid end gland, by pressing down gently and evenly on the edge of the retainer/wash with both thumbs.
12. Withdraw the tool, while holding the retainer/wash and liquid end firmly in place.
13. Reinstall the liquid end on the pump. See Figure 1. Make certain the holes in the retainer/wash line up with the wash ports with the barbed fittings.

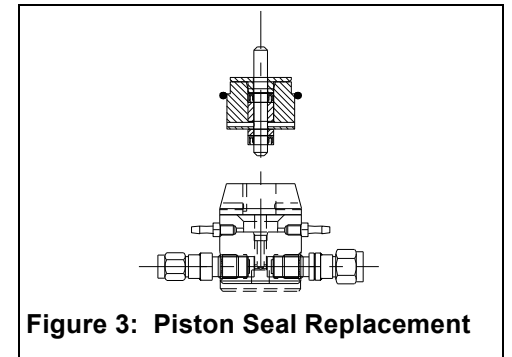

**Figure 3: Piston Seal Replacement**

### PRECAUTIONS:

1. Do not re-use the old piston seal or backup washer.
2. Cleanliness is very important for optimal seal and check valve operation.
3. We have found, especially with metal-free seals, that "breaking-in" the seals with IPA or methanol for an hour or so, under conditions similar to your expected operating conditions enhances seal life.

If there is anything we can do to help you with these instructions, or, if you have comments or suggestions, please contact us at:

**(800) 969-3533.**