

Eldex

Eldex®
Hydrolysis/Derivatization Station
Operator's Manual

Eldex Laboratories, Inc.
30 Executive Court
Napa, CA 94558
Tel: (707) 224-8800
Fax: (707) 224-0688
www.eldex.com

TABLE OF CONTENTS

CONTENTS	Page
I. INTRODUCTION	1
The Eldex Hydrolysis/Derivatization Station	1
About This Manual	1
A Guided Tour of the Eldex Hydrolysis/Derivatization Station	1
Specifications	2
II. INSTALLATION	3
What You Will Need	3
The Unit	3
Operator Supplied Equipment	3
Tools	3
Unpacking	4
Location	4
Electrical Connections	4
Assembly	4
Test Procedures	5
Vacuum Test	5
Reaction vial and cap test	5
Oven Test	5
Nitrogen Source Test	5
III. OPERATION	6
Reagents Required	6
Sample Preparation	6
Evaporation of Solution to Dryness	6
Vacuum-Nitrogen Cycle	6
Continuation	7
Removal of Excess HCl	7
Redrying Procedure	7
Derivatization	7
IV. MAINTENANCE AND ACCESSORIES	8
V. APPENDIX	9
Warranty	9
Return Procedure	9
Trademarks	9

I. INTRODUCTION

The Eldex Hydrolysis/Derivatization Station

The Eldex Hydrolysis/Derivatization WorkStation (H/D WorkStation) is designed to provide convenient hydrolysis and precolumn derivatization

Up to 12 glass sample tubes can be used simultaneously in the reaction vial assembly.

The H/D Station provides for nitrogen and vacuum connections and contains an oven, which holds up to four reaction vials. A cold trap is provided to prevent vapors from reaching the vacuum pump (not included).

About This Manual

Section II of this manual describes the unpacking, location, and initial installation of the unit. Section III covers routine operation. Section IV covers maintenance and accessories. Section V covers warranty and return procedure.

A Guided Tour of the Eldex H/D Station

The Eldex H/D Station consists of:

1. The H/D Station
2. Cold finger tube
3. Cold trap assembly
4. Reaction Vial assemblies (4)
5. Tubing for vacuum and nitrogen connections
6. Power cord

As you look at the front panel of the H/D Station (Figure 1.1), you will see:

1. H/D WorkStation Power Switch
2. Oven Power Switch
3. Nitrogen and Vacuum Connections
4. Vacuum Valve
5. Nitrogen Valve
6. Temperature Set/Read Switch
7. Temperature Adjust Knob
8. Temperature Display
9. Vacuum Gauge

The rear panel of the H/D Station (Figure 1.2) provides access to:

1. Power Entry Module: uses a standard 3-conductor modular power cord.

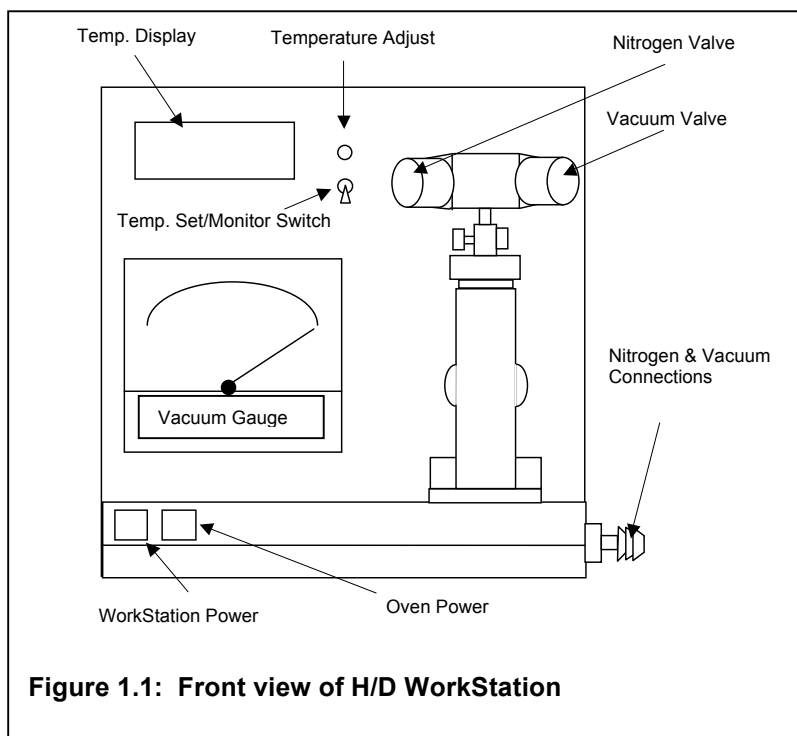

Figure 1.1: Front view of H/D WorkStation

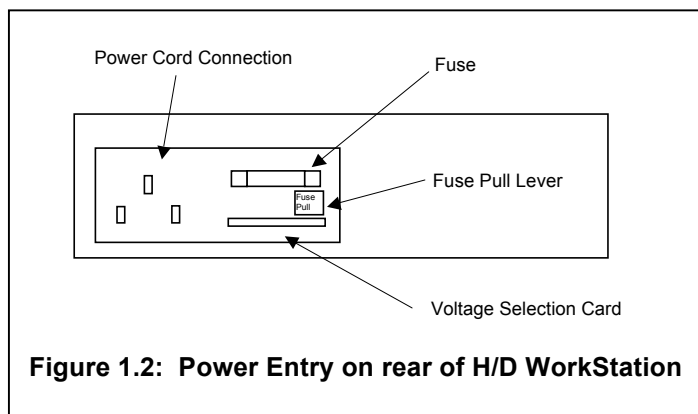

Figure 1.2: Power Entry on rear of H/D WorkStation

Specifications

Dimensions:

Work Station: (L x W x H): 47.0 x 24.4 x 24.8 cm (18.5 x 9 5/8 x 9 3/4 in)

Cold Trap: (L x W x H): 18.4 x 18.4 x 33.0 cm (4 1/4 x 7 1/4 x 13 in)

Weight:

Work Station: 7.47 kg (16.25 lb)

Cold Trap: 4.2 kg (9.25 lb)

Fuse:

100/120V 3.0 A slo-blo

220/240V 1.5 A slo-blo

Oven Temperature Range: 105 – 150°C

Oven Readout accuracy: $\pm 2^\circ\text{C}$

Oven Stability: $\pm 1.0^\circ\text{C}$ (over a 10 min. period)

Oven Repeatability: $\pm 0.5^\circ\text{C}$ of front panel setting

Oven Drift: $\pm 1.0^\circ\text{C}$ (over an 8 hour period)

Oven Sensor location: Aluminum block

Outside case temperature: less than 60°C

Oven Automatic shutoff: $>155^\circ\text{C}$

Vacuum capability: 60 millitorr in 6 min.

Maximum N₂ inlet pressure: 8 psi (0.57 bars)

System volume:

Valve head tubing: 20cc

Cold Finger: 150cc

II. INSTALLATION

What You Will Need

The Unit

The Eldex Hydrolysis/Derivatization Module as shipped consists of two units: the WorkStation itself and the Cold Trap. Your shipment will include:

1. H/D WorkStation
2. Cold Trap Module
3. Vacuum Trap
4. 30 “ long ¼” ID Tygon® tubing
5. 18” long ½” ID rubber tubing
6. 24” long ½” ID rubber tubing
7. Reaction vial assembly (4)
8. Power cord
9. 1.5 A fuse (for 220V operation)
10. 3.0 A fuse (for 110V operation)
11. ¼ A fuse (for over current protection)
12. #7 Viton “O” Ring and #10 Viton “O” Ring

Operator Supplied Equipment

In addition to the above items, you will need:

1. Microliter syringes or adjustable micropipets
2. A nitrogen source (regulated to about 2 psi [0.15 bar])

A Vacuum pump, such as the Welch CVRpro Direct Drive Rotary Van Vacuum Pump, Model CRVpro4, or similar pump with general specifications in the range of:

Free air displacement: 90L/min

Ultimate vacuum: .1 Microns Hg

Motor: 1/3 HP

Efficiency factor: 50% @ 1 Micron Hg

Pumping speed (typical) at high vacuum: 45 L/min @ 1 Micron Hg

3. A thermometer capable of displaying temperatures of 160°C or greater
4. 6 x 50 mm sample tubes (Corning # 9820-6, Kimax # 45048-650, or Kimble # 45060-650)
5. Dow Corning® 111 silicon grease (or other high vacuum grease)
6. Dry ice
7. 2-propanol
8. Reagents

Tools

No special tools are required to assemble or use the H/D WorkStation. In addition to the above, you will want to have on hand:

1. Teflon® forceps
2. Plastic gloves

3. A razor blade to cut the tubing
4. Insulated gloves
5. Needle nose pliers to change voltage selector card position (if necessary)

Unpacking

The H/D WorkStation, Cold Trap, reaction vials, and ¼” Tygon tubing are shipped in the same box along with the power cord. Before attempting to operate the H/D WorkStation, unpack all items carefully. Do not discard any packing material until you have carefully checked the items for damage. If any damage is evident, you should contact the freight company that delivered the unit to file a claim.

Location

The H/D WorkStation and associated components should be used in a well-ventilated environment free of corrosive or explosive vapors.

Electrical Connections

The WorkStation is shipped configured for operation at 115V. The configured voltage appears on the left side of the voltage selector card. Refer to Figure 1.2 to change the set voltage.

To change the voltage:

1. Move the plastic window to the left.
2. Remove the voltage selector card using needle nose pliers, or insert a ballpoint pen into the hole in the front of the card, and pull gently.
3. Position the voltage selector card to show the appropriate voltage on the left side and re-insert the card.
4. Pull the fuse pull lever to the right to install the proper size fuse.
5. Move the plastic window to the right.

Assembly

1. Make certain both valves (nitrogen and vacuum) on the WorkStation are closed completely (clockwise). Figure 2.1 schematically illustrates the various connections in the H/D Module assembly.
2. Assemble cold finger tube and housing using Dow Corning® 111 or other high vacuum grease.
3. Insert assembled cold finger into cold trap.
4. Connect cold finger outlet with the vacuum pump with a piece of 1/2” I.D. rubber tubing.
5. Connect cold finger inlet with the vacuum fitting on the WorkStation (using 1/2” I.D. rubber tubing).
6. Connect nitrogen source to the nitrogen fitting (using ¼” Tygon® tubing).
7. With all tubing securely connected, plug the WorkStation power cord into an appropriately rated, grounded outlet and turn the power switch on.

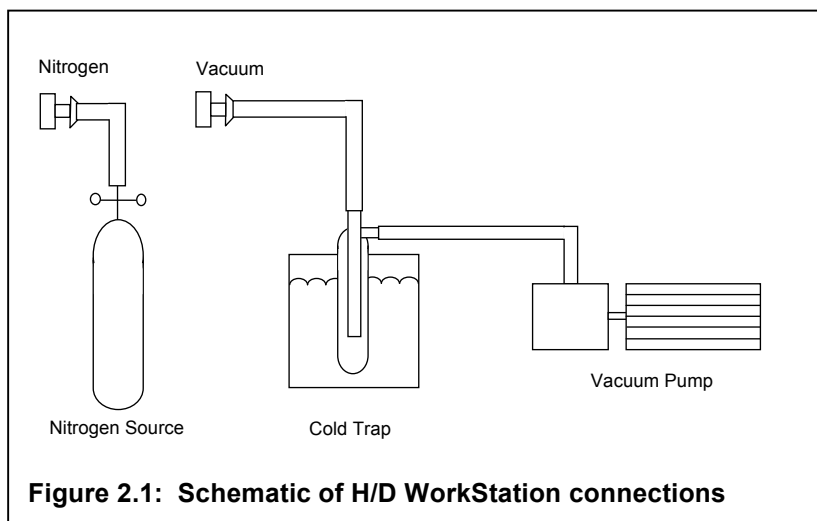

Figure 2.1: Schematic of H/D WorkStation connections

Test Procedures

A. Vacuum Test

1. Fill the cold trap with dry ice and carefully add 2-propanol to fill the trap (you can use a cryogenic cooler to cool the propanol). Allow cold trap to cool (about 5 minutes).
2. Turn on the vacuum pump according to the manufacturer's instructions.
3. Within about two minutes, the vacuum gauge should read about 60 millitorr. If the vacuum gauge does not read 60 millitorr, check the tubing connections, making sure that the vacuum valve is closed. If your system does not reach 60 millitorr, the pump oil may be contaminated.

B. Reaction vial and cap test

1. Place a reaction vial with cap into the valve port.
2. Push the RED button in and note the vacuum as indicated on the gauge.
3. Open the vacuum valve.
4. The vacuum gauge will rise and will then slowly come back down to the same vacuum as before the valve was opened. Note the gauge reading.
5. Open the reaction vial by pushing the green button in on the vial cap.
6. The pressure will now rise rapidly, then slowly drop back to the vacuum as noted.
7. Problems in with steps 4, 5, or 6 indicate a leak in the interface between the vial cap and the WorkStation, or in the cap, or in the seal between the cap and the vial.
8. Follow the vacuum pump manufacturer's instructions for shut down procedures. The vacuum gauge should read ATM.

C. Oven Test

1. Open the oven door. Place a thermometer with a rating of $\geq 160^{\circ}\text{C}$ in the central cavity.
2. Turn the oven on. Hold the temperature set switch in the SET (up) position and adjust the temperature to indicate 105°C on the temperature display. Release the switch.
3. Within approximately 20 minutes, the thermometer should read 105°C .
4. Hold the temperature set switch in the SET (up) position and adjust the temperature to indicate 150°C on the temperature display. Release the switch.
5. Within approximately 20 minutes, the thermometer should read 150°C .
6. Turn the oven off.

D. Nitrogen Source Test

1. Using appropriate safety equipment (safety glasses, gloves, etc.), close the valve on the regulator for the nitrogen source. Be sure that the "T" handle on the regulator valve is turned counter-clockwise until it feels loose.
2. Open the valve on the nitrogen source.
3. Turn the "T" handle clockwise to adjust outlet pressure to 2 psi (0.14 bars). In no case is outlet pressure to exceed 8 psi (0.5 bars).
4. Open the valve on the regulator to allow nitrogen to enter the system.
5. Check for leaks on all tube fittings.
6. Turn off the valve on the nitrogen source.
7. Open the nitrogen port (counter-clockwise) on the WorkStation to relieve the remaining gas pressure.

III. OPERATION

Reagents Required

6 N HCl with 1% phenol by volume.

Nitrogen (pre-purified grade).

Methanol.

Dry Ice.

Sample Preparation

Clean the sample tubes with an acid such as 6 N HCl. Rinse thoroughly with water, then 100% (undenatured) ethanol and dry under vacuum. You may scribe the sample tubes with a diamond pencil before placing them in the reaction vial for identification purposes.

Use a syringe or micropipet to place a solution containing 0.5 – 10 μg of the sample into the sample tubes. As many as 12 sample tubes may be placed in a single reaction vial. The sample tubes should be handled with Teflon® forceps or with plastic gloves to prevent contamination by skin contact.

Turn the oven to 105°C 20 to 30 minutes before performing the hydrolysis to allow the oven to equilibrate.

Evaporation of Solution to Dryness

Place dry ice in the Dewar flask around the cold finger. Carefully add methanol or 2-propanol to the cold trap. Turn on the vacuum pump.

Screw the reaction vial cap onto the vial. Slide the button on the cap to the open (green in) position. Install the reaction vial onto the WorkStation by positioning the top of the vial in the vacuum port and slide the bottom of the vial in toward the WorkStation on the black “shoe”. Open the vacuum valve.

Once the vacuum gauge reaches about 65 millitorr, the samples are properly evaporated. Allow the system to stay at this reading for several minutes for additional drying.

Close the vacuum valve and remove the reaction vial from the WorkStation. Unscrew the cap from the vial.

200 μL of HCl/phenol should be pipetted into the bottom of the vial. Take care not to introduce the HCl directly into any of the tubes.

With the reaction vial cap in the open (green in) position, screw the cap onto the vial and install the vial onto the WorkStation.

Vacuum-Nitrogen Cycle

Check to be certain the nitrogen valve is closed and carefully open the vacuum valve until the vacuum gauge reads about 1-2 Torr and the HCl begins to bubble. The procedure will take about 20-30 seconds.

Close the vacuum valve.

Open the nitrogen valve and purge for 5 seconds. Close the nitrogen valve.

Repeat the Vacuum-Nitrogen cycle for three cycles. Leave the vacuum valve open after the last cycle.

Do not evaporate the acid to dryness. If the vacuum gauge falls below 500 millitorr, discontinue purging.

Continuation

While the vial is under vacuum, close the vial cap valve (red in). Close the vacuum valve and remove the vial from the WorkStation.

Place the reaction vial in the oven. Use gloves or forceps to avoid contacting the oven interior. The vacuum and nitrogen systems of the WorkStation can now be turned off as described in the Test Procedures.

Removal of Excess HCl

After 20-24 hours, remove the vial from the oven to cool. Open the vial cap valve (green in). Remove the reaction vial cap and carefully remove the sample tubes with Teflon coated forceps. Use laboratory wipes to remove the HCl from the outside of each tube. Transfer sample tubes to a fresh reaction vial.

Screw a reaction vial cap onto the vial. Open the vial cap valve (green in). Install the reaction vial onto the WorkStation and carefully open the vacuum valve.

Once the vacuum gauge reaches about 65 millitorr, the samples are properly evaporated. Allow the system to stay at this reading for several minutes for additional drying.

Redrying Procedure

Activate the vacuum system as described in Test Procedures.

Make a suitable volume of the redrying solution (ethanol: water: triethylamine in a 2:2:1 mixture by volume) and add 10 μL to each of the sample tubes. Shake gently or vortex to mix.

Screw the reaction vial cap onto the vial. Open the vial cap valve (green in). Install the reaction vial onto the WorkStation.

Carefully open the vacuum valve. When a reading of about 65 millitorr is reached on the vacuum gauge, the samples are properly evaporated.

Close the vacuum valve and remove the reaction vial from the WorkStation. Unscrew the reaction vial cap from the vial.

Derivatization

Prepare the reagent for derivatization for each analysis. The reagent used is a 7:1:1:1 solution by volume of ethanol: triethylamine: water: phenylisothiocyanate (PITC). The reagent is prepared by using a suitable syringe or micropipet to transfer 70 μL of ethanol into a fresh sample tube. 10 μL each of triethylamine, water and PITC is added. The solution is then vortexed for a few seconds.

Add 20 μL of the derivatization reagent to each sample tube. Vortex each tube for a few seconds. Place the tubes in a reaction vial and let stand for 20 minutes at room temperature.

Install the reaction vial onto the WorkStation. Carefully open the vacuum valve. The vacuum gauge should read about 65 millitorr within a minute or two. Allow the vial to dry for about ten more minutes to insure removal of the last traces of PITC.

Close the vacuum valve and remove the vial from the WorkStation. The samples are now ready for HPLC analysis. If it is not possible to process the sample tubes at this point, they are best stored in a refrigerator in the dry state and the reaction vial is a convenient container.

IV. MAINTENANCE AND ACCESSORIES

The H/D WorkStation requires little maintenance when following the procedures outlined in the manual.

Following is a list of commonly used spare parts (also included are Waters® old part numbers):

Eldex P/N	Waters P/N	Description
1163	WAT007363	Reaction vial assembly
1205	WAT007498	Tubing .251 ID Red Gum, 10 ft.
3447	WAT007497	Tubing .5 ID Rubber, 2 ft.
1206	WAT007499	Tubing .251 ID Tygon, 10 ft.
1208	WAT007566	Vacuum gauge assembly
2990	WAT007486	Tube Port
2993	WAT007487	Port Tube plug
3000	WAT007568	Reaction vial (40 mL)
3002	WAT007569	Reaction vial cap

For other parts, consult Eldex.

Eldex Laboratories, Inc.
30 Executive Court
Napa, CA 94558
Toll Free: (800)969-3533
Telephone: (707)224-8800
Fax: (707)224-0688
www.eldex.com

V. APPENDIX

Warranty

Eldex products are guaranteed against manufacturing defects for one year from the date of shipment. Parts and labor are both covered under the warranty. Disposable items are not included in the warranty. The warranty does not apply when there has been obvious misuse or mistreatment by the user or when damage has been caused by attempted repairs by the user. Exposure of Eldex products to inappropriate chemicals also voids the warranty.

Eldex Laboratories, Inc. will not assume responsibility for contingent liability through alleged failure(s) of its products.

There are no warranties, express or implied, which extend beyond this description. Eldex neither assumes, nor authorizes any person to assume for it, any other liability in connection with the sale and use of the products.

Damages are limited strictly to repair or replacement of the products. Eldex expressly disclaims liability for incidental and consequential damages resulting from the use of the products.

Return Procedure

To return an instrument for repair, contact our factory at (800)969-3533 or (707)224-8800 to obtain authorization. Describe the problem with the instrument to our factory personnel and receive a Return Authorization Number. Reference the number on the outside of the packing box in which you return the instrument. Also reference the Return Authorization Number on any paperwork you send with the unit. Be sure to enclose a brief note describing the problems, reference the serial number of the unit, and describe any chemicals used. Also reference your return address. Send the instrument freight prepaid to:

Eldex Laboratories, Inc.
30 Executive Ct.
Napa, CA 94558-6278

Trademarks

Eldex, Eldex Laboratories, Inc.; Tygon, Norton; Teflon, DuPont; Waters, Waters Associates

